

# 인체감지센서

## Passive Infrared Detector HNIR-550

### SPECIFICATIONS

Infrared sensor.....	Dual element
Power supply .....	9 ~ 16 VDC, 12V typical
Current drain.....	N.C:5 mA, N.O:15 mA, 12VDC
Alarm output .....	N.C/N.O 30VDC, 0.2A max.
Alarm period .....	1.5 ~ 2.5 sec.
Pulse count .....	2 / 3 selectable
Tamper switch .....	N.C cover open activates
Walk test LED.....	Red, can be disabled
RFI immunity.....	Ave. 20V/m (10~1000 MHz)
Detectable speed.....	0.3 ~ 1.5m/sec.
Mounting height.....	2.2 ~ 3.6m
Humidity.....	95% RH maximum
Temperature .....	-20°C ~ 60°C (-4°F ~ 140°F)
Dimensions .....	112 X 66 X 45 mm
Unit weight.....	86 grams

\* Specifications subject to change without prior notice.

### INSTALLATION HINTS

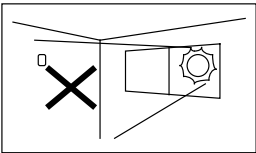

Do not install where the detector is in or facing direct or reflected sunlight, windows onto main roads (car head lights).

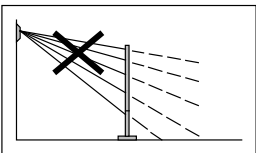

Ensure that there are no obstructions (plants, screens, furniture etc.) in the field of view, which may cause incorrect cover/operation of the detector.

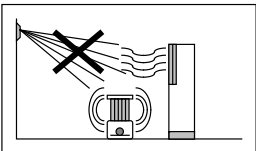

Avoid locating the detector in areas, which contain equipment that may change the environment temperature rapidly.

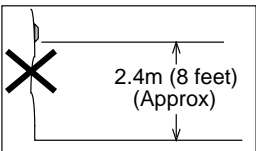

Install the detector at the recommended height on a rigid surface.

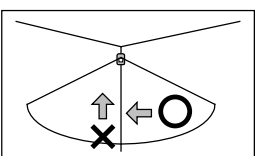

PIR detector is more sensitive to the motion "across" the detection zones than "toward" the unit.

# HANA Engineering Installation Instructions

### DESCRIPTION

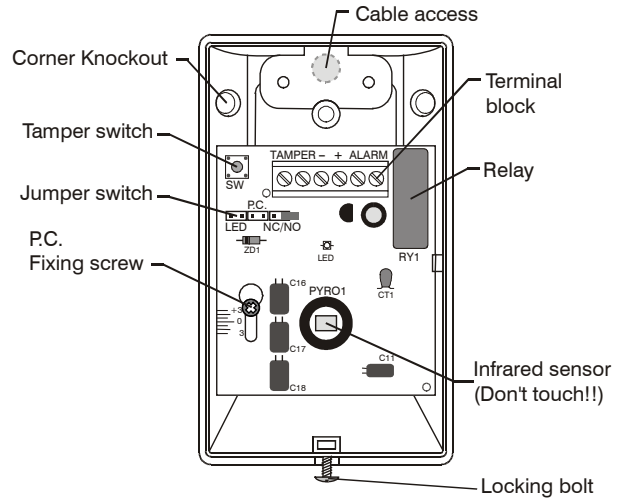

### MOUNT WITH BRACKET

#### Ceiling Mount

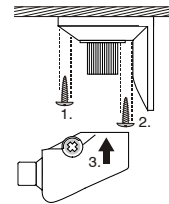

#### Wall Mount

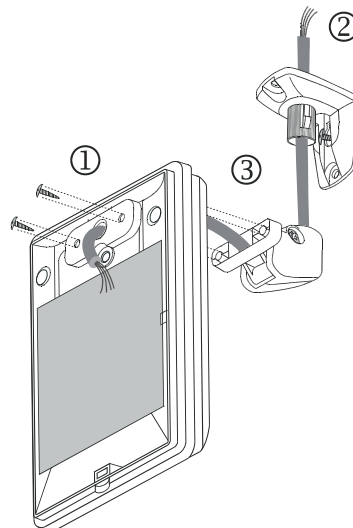
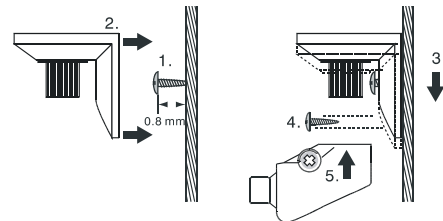

# INSTALLATION & WIRING

## Installation (without using bracket)

1. Open the front cover by loosening the screw at the bottom of the unit. Remove the PCB from the unit base. Mount the base firmly on the selected position with at least 2 screws.
2. Replace the PCB at factory set position (0). Connect the signal cables to the corresponding terminals according to the following instructions.

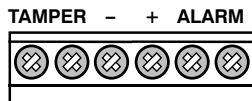

- , + : 9 ~ 16 VDC power supply
- ALARM** : Zone input of control panel (N.C/N.O)
- TAMPER** : 24 hours N.C. loop of control panel

4. Replace the front cover, apply power supply to the detector and conduct the walk test.

## WALK TEST

The walk test should be carried out to ensure the detection coverage is adequate. Apply DC power to the detector and wait approx. 30 seconds for it to warm up and stabilize. Walk across the detection zones at normal speed. The LED will lit whenever it detects the movement. The LED display can be disabled by pulling off the jumper head the PCB pins labeled "LED".

Verify correct operation of the detector by conducting a walk test at least once a year.

ON  
 OFF

## PULSE COUNT

The PEGASO features an intelligent pulse count that reduces the possibility of false alarm caused by environmental and power line interference. The pulse count can be set to count 2 or 3 pulses by placing the jumper head on the corresponding pins. An alarm signal will only be sent when the selected pulses are generated within delay time of 20 seconds. IR-TEC's intelligent pulse count circuitry analyzes the width difference of pulse signal. When human motion is detected a subsequent pulse signal will over-ride the pulse count setting and generate the alarm signal without any delay.

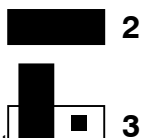

## ALARM OUTPUT SELECTOR

The alarm output can be changed to N.O by removing the jumper from N.C/N.O selector. N.O output can be applied to activate VCR of CCTV systems or other facility.



## ADJUSTMENT

The detection beams can be adjusted vertically by sliding the PCB up or down. When unit is mounted higher than 2.4m (8 feet), you may need to slide the PCB upwards to aim the detection beams downwards. Following table provides reference of PCB position and respective detection coverage.

M/H	1.8m	2.0m	2.2m	2.4m	2.6m	2.8m	3.0m
B/P	Maximum Detection Coverage(m)						
+3	15	11	9	5	5	6	6
+2	15	15	13	13	10	10	6
+1	15	15	15	15	15	15	15
0	15	15	15	15	15	15	15
-1	15	15	15	14	15	15	15
-2	13	13	14	14	15	14	14

M/H: Mounting Height B/P: PCB Position

## DETECTION PATTERN

### IR-550

110°, 15 x 15m at 25°C

Top View

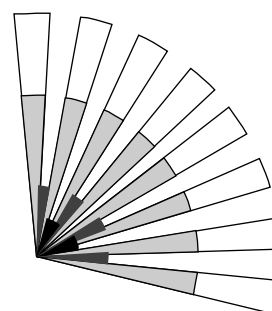

Side View

