

UNIGUARD UG-2-A2 STAND-ALONE-UNIT

Smoke detector with service alarm for duct installation.

CE 6.0.3.E-P



- One-tube air sampling system
- Service alarm
- Test hole on cover
- Simple installation
- Sensitive flow indication
- Filter for dusty environments
- Simple service and maintainance
- Installer-friendly connection of cables
- Foolproof mountage of sampling tube
- Reset button on front cover
- Built-in alarm relay

TECHNICAL DATA

Detector type:	Ionisation - UG-2-A2I Optical - UG-2-A2O
Voltage Supply:	24VAC 100 mA \pm 20%
Operating temperature:	-10°C to +50°C
Maximum humidity:	99% rH
Tested and approved according to EN-54:	by LPC (England)
Service alarm:	Indicated with green LED
Fire alarm:	Indicated with red LED
Adaptor housing:	ABS
Air sampling tube:	Aluminium. Standard length 600mm. Hole diameter 35mm.

ACCESSORIES:

Filter:	F1-UG/10 pack
Tubes:	Venturi 1,5 m (Ducts 600-1300 mm) Venturi 2,8 m (Ducts larger than 1300 mm)
Mounting bracket:	UG-Beslag (For insulated/circular ducts)
Waterproof housing:	UG-SH for outdoors, in cold attics etc. IP 65.

FUNCTION:

Uniguard has been developed to detect smoke in ventilation ducts and combines a smoke detector and an adaptor system where both tube and housing are specially designed for optimum airflow through the smoke detector.

The system fulfils all the requirements for safe fire detection with airflow speeds from 0,2 m/s to 20 m/s.

Uniguard has a built-in alarm relay to control fire-safety dampers, to stop ventilation fans, or to activate accoustic and optical alarms etc.

The service alarm let you know when maintenance is needed, before a false alarm occur.

The detector has a bayonet fitting to simplify mounting and removal.

A contaminated detector will result in increased sensitivity and false alarms. To avoid nuisance alarms the detector has a service alarm (green LED). This indicates that the detector should be cleaned.

BASIC PRINCIPLES FOR POSITIONING:

For the airflow through the adaptor to be representative of the airflow in the ventilation duct, install the detector at a place where normally flow meters etc. should be mounted, please see our installation instructions.

Or use the national or local rules for moutage according to "Methods for measuring airflow in ventilation systems".

UNIGUARD UG-2-A2 STAND-ALONE-UNIT

Smoke detector with service alarm for duct installation.

6.0.3.E-P

INSTALLATION:

The venturi tube is made of aluminium and can easily be shortened to suit the diameter of the duct. Hole diameter is 35 mm. With insulated or circular ducts - use the mounting bracket, hole diameter is then 48 mm.

MAINTAINANCE:

When the detector becomes contaminated, sensitivity is increased, triggering the service alarm. This can be avoided for a considerable time by cleaning the detector once a year with a vacuum cleaner.

CHECKING AIR FLOW

The detector is equipped with a flow indicator which oscillates in the air stream when the detector is correctly installed. This gives simple confirmation that there is no leakage, and that air from the ventilation duct is flowing through the detector.

FUNCTION TEST:

When installation is complete, the detector should be tested. This can be carried out with smoke or suitable testspray for example RDP-300 (from Calectro), use the test hole on cover. Do not forget to refit the plastic plug after test.

NB: When installing outdoors or in cold attics etc., where there is a risk for condensation, this requires that the detector is insulated from the surrounding air by means of for example our waterproof housing UG-SH, and marked with an extra indicator lamp, LED-01 and a sign marked "Hidden Detector".

FUNCTION:

- Normal operation:** In normal operation the alarm relay is energized, and the relay contacts are closed between C and NC.
- Smoke alarm:** The LED of the detector is showing red light and the relay contacts are changing to C and NO.
- Reset:** After alarm the reset push-button has to be pressed in order to have the detector back into normal operation.
- Pre-alarm:** When the detector is sensing smoke or is dirty the LED of the detector will first show green colour before going into alarm with red light. If the detector is dirty, it will show green light. This is an optical indication (a pre-alarm or service-alarm) which means that the detector is contaminated and if it is not cleaned, it will later on give a false alarm.
- Failure:** If there is something wrong with the detector, the alarm relay will change contacts:
a) If the detector module is taken away
b) If the supply voltage is interrupted

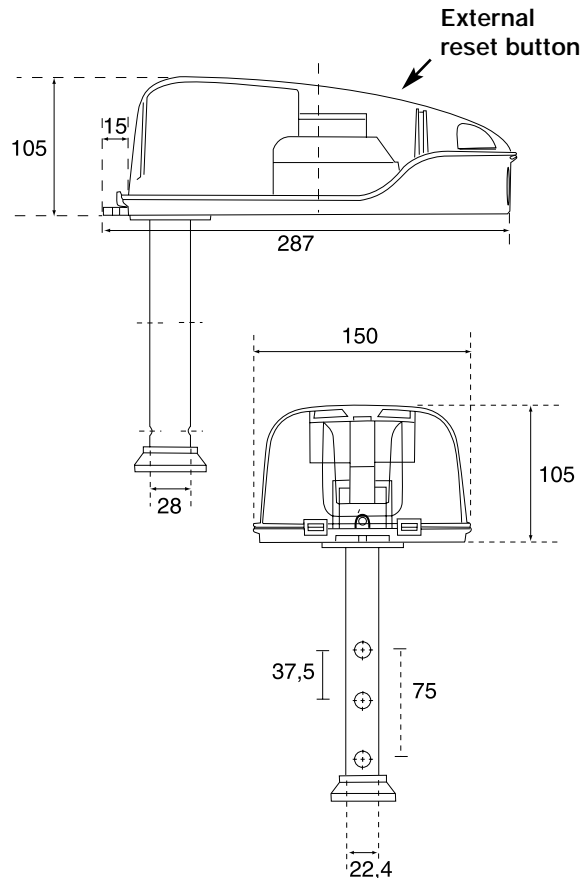

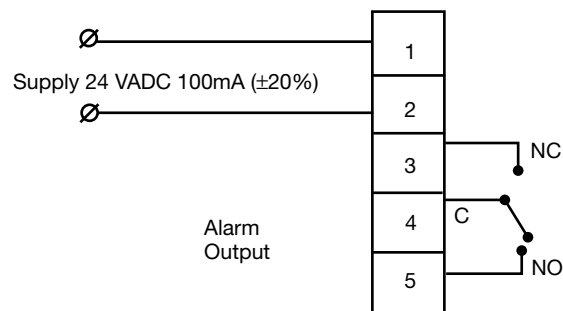

WIRING DIAGRAM



Alarm relay: ONE changing contact, max 250V, 2Amp

Note! Changing between AC and DC is made by a jumper.

 = 24 VDC

 = 24 VAC

The jumper is factory set to AC.